



PyrolysisUnit environmentally
friendly pyrolysis equipment
solution

ABOUT PYROLYSIS UNIT

- Our company specializes in the treatment and production of waste rubber, waste oil, waste engine oil, and continuous carbonization furnaces. Guided by the philosophy of "eliminating black-and-white pollution and benefiting future generations," we actively promote a management spirit centered on "people-oriented values, focusing on personal cultivation; independent research and development, efficiency, and pragmatism." With meeting customer requirements as our ultimate goal, we pursue the integration of efficiency and development. We look forward to collaborating with you in the near future.



Our product



连续式炭化炉
CONTINUOUS
CARBONIZATION FURNACE



卧式炭化炉
HORIZONTAL
CARBONIZATION FURNACE



粉碎机
CRUSHER



压球机
CHARCOAL BALL
BRIQUETTE MACHINE



木炭机
BIOMASS
EXTRUDE MACHINE



煤棒机
CHARCOAL
EXTRUDE MACHINE

Workshops



Flow chart and layout drawing

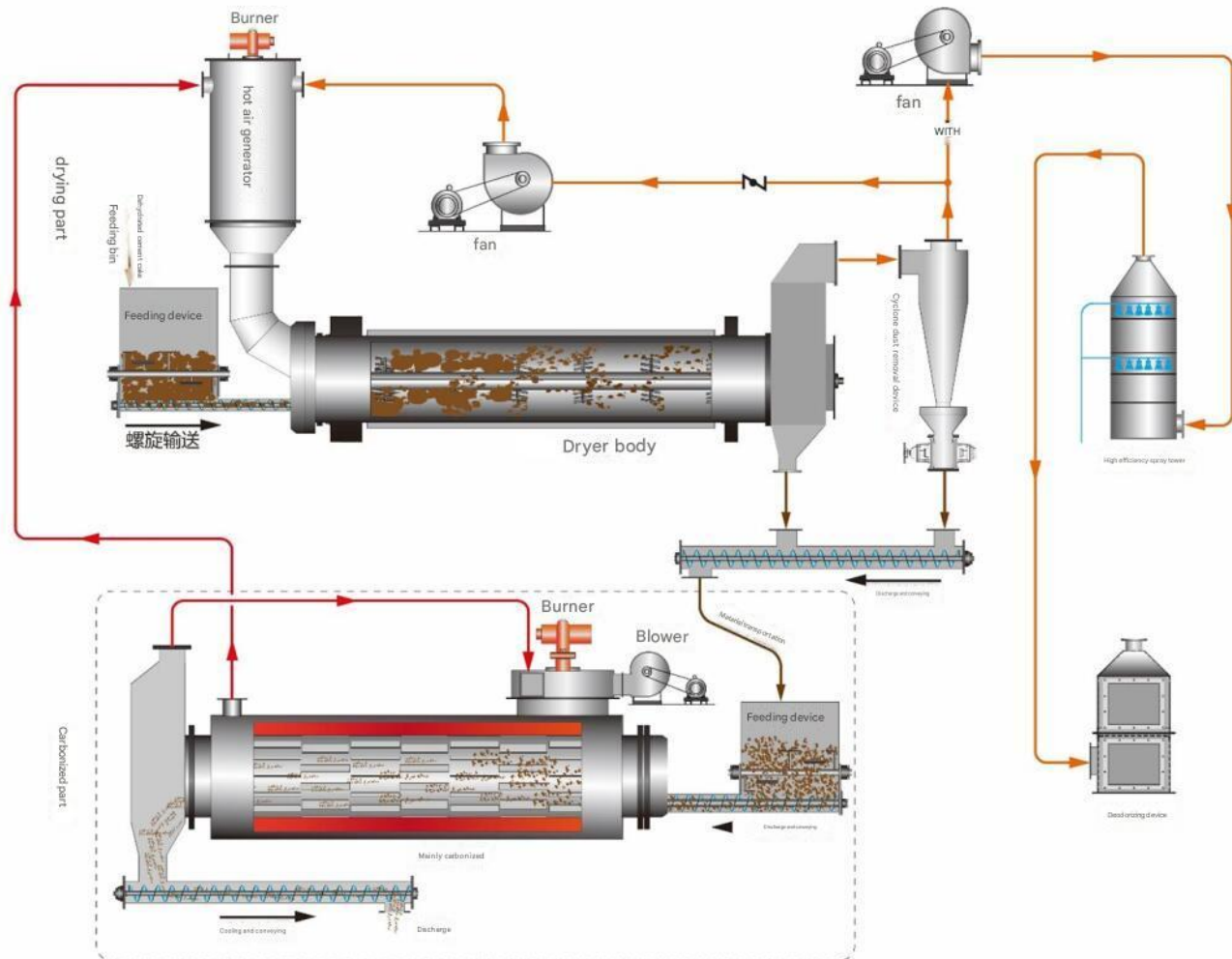

SRAW MATERIAL



coconut shell



palm shell



sawdust



bamboo



corn cob



rice husk



straw



wood

SRAW MATERIAL



Final Product



Uses of Charcoal

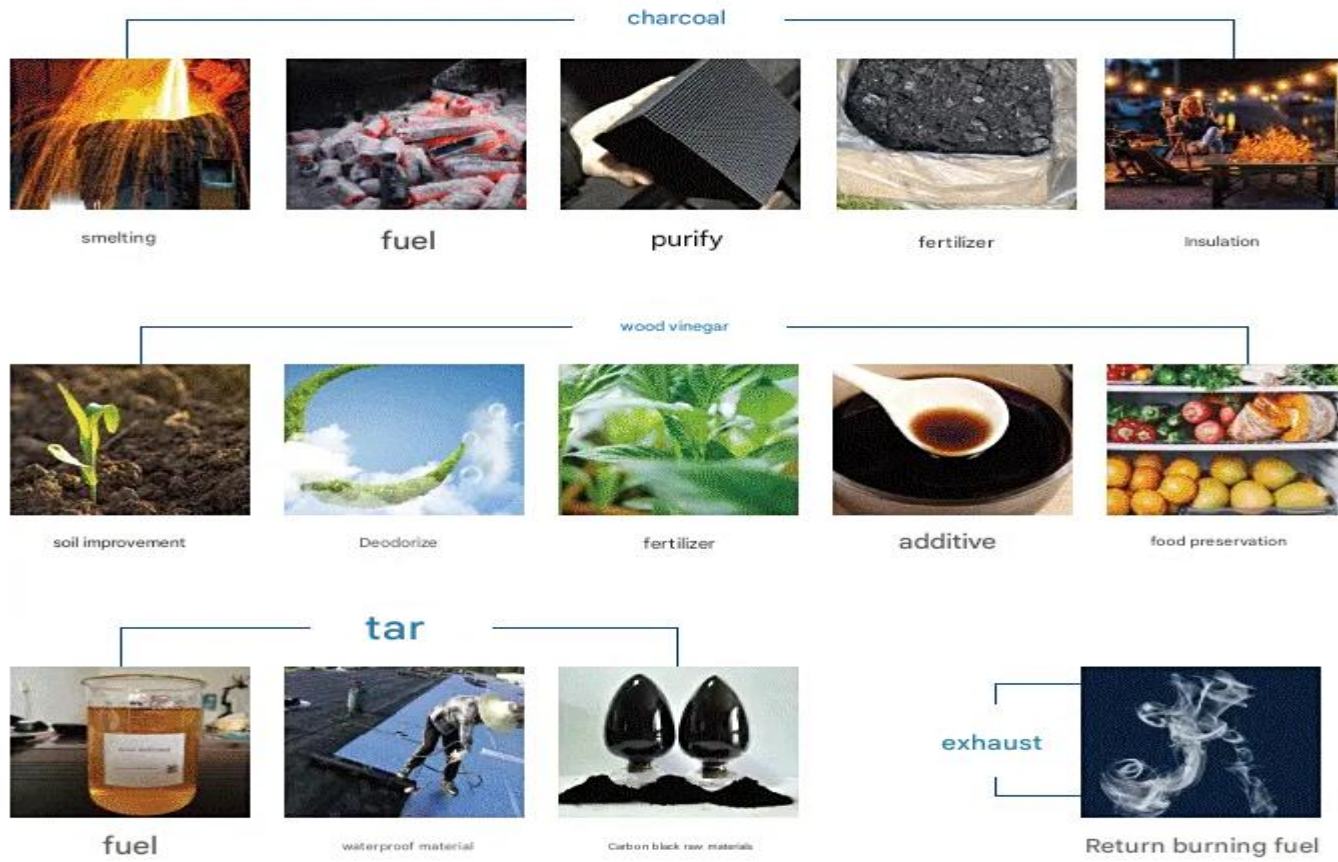

Equipment details



Customer Case



Model

| MODEL | PUTHL-1 | PUTHL-2 | PUTHL-3 | PUTHL-4 |
|---------------------------------------|----------------|----------------|----------------|----------------|
| Diameter(MM) | 800X1000 | 1000X1200 | 1200X1200 | 1500X1000 |
| Yield(KG/H) | 300 | 600 | 800 | 1000 |
| Liquefied gas burner | 5 | 6 | 9 | 12 |
| Carbonization furnace temperature(°C) | 350-850 | 350-850 | 350-850 | 350-850 |
| Fan | 15 | 22 | 30 | 35 |
| Main burner | 1 | 1 | 1 | 1 |
| Carbonization furnace main unit (KW) | 4 | 5.5 | 7.5 | 11.5 |

Shipping

